



NEWSLETTER

1926 - 2026

This Month

BRAVA Modular Euro Cylinder System

Futura M: Smarter, Quieter & Built to Last

The Melbourne Homeshow 2026

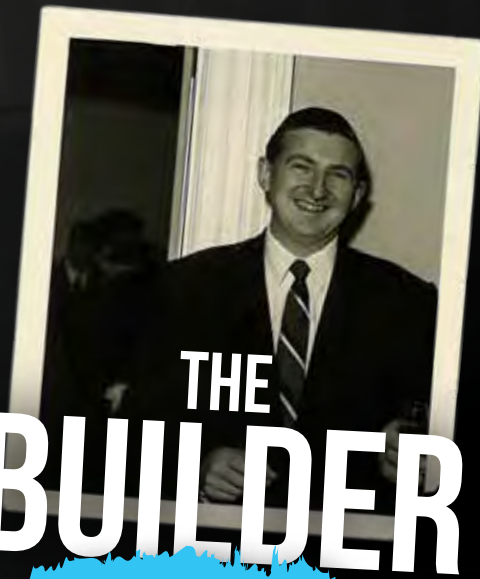

THE BUILDER

Stuart's Era



Locksmiths Supply Co

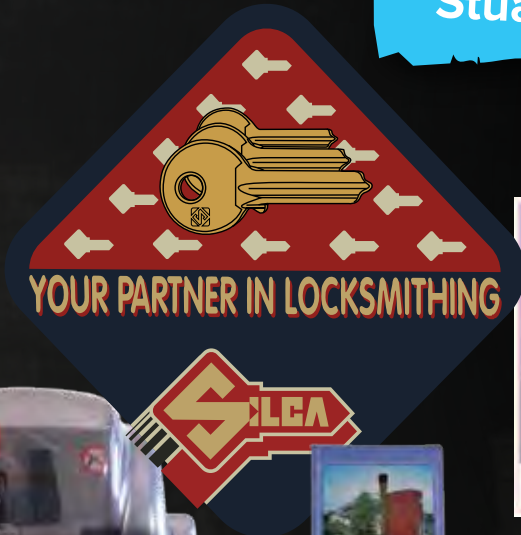

Stuart's values:

1) Go help the customer

2) Product knowledge is all-important

3) Do what you said you were going to

J. Johnson

Broadening Horizons:

The Road to Silca

From the April issue, I wrote about how my father, Stuart Johnson, built momentum in the business through the 1950s and 1960s, establishing strong relationships across Australia which help to shape LSC's national presence.

By the late 1970s, the industry was changing. The Australian market required an increasingly broad range of key blank profiles, many of them low-volume, making it uneconomical for local manufacturers to keep pace. At the same time, competition was intensifying.

The challenge was clear: to properly service the Australian market you needed access to thousands of profiles, but the volumes simply didn't justify local production. We could no longer rely on EzyCut alone. A new approach was needed.

That turning point came in 1977 at the ALOA trade show in Albuquerque, where my father met a young Italian, Massimo Bianchi, whose family owned Silca. At the time, Silca was Europe's largest manufacturer of key blanks and machines. That meeting would prove pivotal.

Silca was not entirely unknown in Australia, with small volumes of blanks and machines previously imported. However, it was my father's ability to form a direct partnership with Silca that changed everything, establishing a relationship that would span almost 50 years.

In the early years, Silca played second fiddle to EzyCut, but its reputation quickly grew. Locksmiths began to recognise the quality and precision of Silca machines, with features such as sealed roller bearings, precision-machined reversible jaws, semi-automatic operation and high-quality milling cutters which set a new standard for the industry.

As awareness increased, so too did the appeal of Silca's extensive range, offering over 3,000 profiles locally and more than 10,000 globally. In a market where range mattered as much as reliability, Silca provided a compelling solution.

I joined the business in 1982, initially planning to stay for a short period. That quickly changed. I found an immediate affinity with both the locksmithing industry and the dynamic world of importing and distribution, a space that was becoming increasingly competitive.

Around this time, it became clear that Silca had overtaken EzyCut as our predominant brand, and we began actively positioning the Italian manufacturer as the number one choice in Australia.

The introduction of Silca marked more than just a new product range - it signalled a strategic shift that would help shape the future of LSC.



Mark Johnson

To be continued..

ABUS HASP & STAPLE RANGE

An easy locking solution for that tough application



ABUS have a wide range of hasp and staples including standard, medium security and high security.

Whether you're locking gates, toolboxes, letterboxes, cabinets, lockers, sheds or cages and kennels, ABUS hasp and staples are the perfect solution.

With a full range of lengths or hinged versions you're sure to find an easy locking solution for that tough application.

FEATURES:

- Wide range
- Hinged versions available
- Superior corrosion protection
- Boxed or display packed
- Hardened staple and concealed hinge pins on certain models
- Supplied with screws and fitting accessories
- Made in Germany



10060C



10080C



100100C



100DG100C



20075C



20095C



200115C



200135C



200155C



110195C



110155C



125150C



130180

INTRODUCING THE BRAVA MODULAR EURO CYLINDER SYSTEM



Euro cylinder locks have become a staple in the industry, with more doors arriving from overseas fitted with pre-installed locks and offset cylinders. At LSC, we understand the need for a user-friendly, field-changeable solution that works seamlessly with LW4, LW5, and inline restricted keying systems.

No more searching for hard-to-source extended cylinders or dealing with difficult offset cylinders in limited keyways. With the BRAVA Modular Kit, you're in complete control. The BRAVA Modular Cylinder allows easy offset adjustments using 5mm, 10mm, 15mm, and 20mm extension increments, giving you the flexibility to configure cylinders on-site to suit a wide range of door applications.

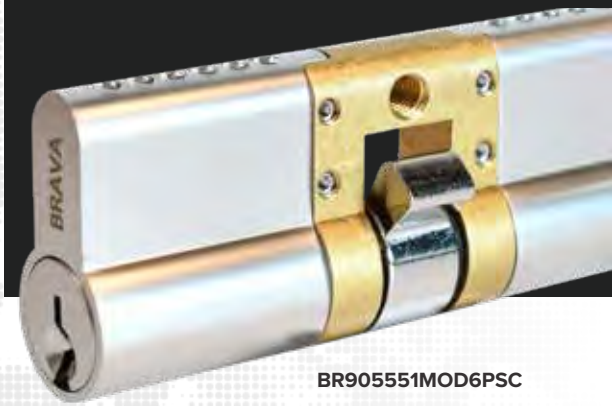

BR905551MOD6PSC



- 6 pin double euro cylinder
- Fixed cam
- Supplied keyed to differ with 2 keys
- Cylinder length 84 mm
- Compatible with most inline restricted keying systems
- Finished in satin chrome

See the full range online!

BRAVA MODULAR KIT

BR90555MODKIT1



EXTENSIONS



BR90555MODEXT5MM



BR90555MODEXT10MM



BR90555MODEXT15MM



BR90555MODEXT20MM

CYLINDERS



BR905551MOD5PSC



BR905551MOD6PSC



BR905552MOD5PSC



BR905552MOD6PSC

KEYED SECTIONS



BR90555MOD6PLPSC



BR90555MOD6PKDSC



BR90555MOD6PKDPC



BR90555MOD6PKDSB



BR90555MOD6PKDPB



BR90555MOD6PKDMB

CENTRE SECTIONS



BR90555COGMODCENTRE
Fixed Cam cog wheel centre



BR905551MODCENTRE
Fixed cam double cylinder centre



BR905552MODCENTRE
Fixed cam cylinder & turn centre



BR905553MODCENTRE
Lazy cam double cylinder centre

Grab your BRAVA Modular kit today and start customising cylinders with ease. Plus, every part is available individually, so you can always stay stocked up.



GO ELECTRIC WITH DORMAKABA

Buy dormakaba products for your chance to win a **BYD ATTO 1 RRP \$23,990**

HOW TO ENTER: Earn one (1) entry for every \$1,500 (ex. GST) spent on dormakaba products between 1st May - 30th June 2026. No limit to the amount of entries per customer. The MORE you spend the MORE chances to WIN!

BONUS ENTRY: Earn a BONUS ENTRY when you buy a dormakaba TS98 door closer (DKTS98XEA)

*Terms & Conditions: "Drive with dormakaba" giveaway promotion runs from 01/5/26 to 30/06/26 and is exclusive to LSC locksmith clients. The \$ spend of \$1,500 ex GST will be calculated for the entire months of May and June 2026 only. For a list of terms and conditions go to <https://www.lsc.com.au/go-electric-with-dormakaba>



TS83 Door Closer
DOTS8300SIL



TS93B Door Closer
DOTS93BN



BONUS ENTRY
TS98 Door Closer
DKTS98XEA

PRODUCT SPOTLIGHT

visit lsc.com.au to explore our popular range of replacement remotes!

POPULAR REPLACEMENT REMOTES FROM TRUSTED BRANDS

Shop our popular replacement remotes from trusted brands like Merlin and B&D - an easy add-on sale for your customers.



Merlin Garage Door Remote with 4 Buttons in Black
RH1009



Merlin Garage Door Remote with 4 Buttons
RH1080



ATA Triocode Garage Door Remote with 4 Buttons
RH2006



B&D Tri-Tran+ Garage Door Remote with 4 Buttons in Red
RH3005



Gliderol Garage Door Remote with 3 Buttons in Black
RH4001



ATA Securacode Garage Door Remote with 4 Buttons in Blue
RH2002

MCGRATH SMART LOCKS KEYSAFE

The KEYSAFE by McGrath Smart Locks is a stylish and feature rich key box that can be used to securely store a spare key or access card to your property.

The Keysafe by McGrath Smart Locks combines durability and flexibility to suit each user's lifestyle, allowing access via fingerprint, PIN code, RFID credentials, Bluetooth eKeys or a mechanical key override. Powered by TT Lock, the Keysafe operates through the McGrath Smart Locks app, where lock settings are easily configured and managed. Particularly well suited to applications such as holiday rentals, permanent, timed, recurring or one-time access can be granted to guests, family or visitors via PIN codes, RFID credentials or Bluetooth eKeys.

MLKSBK



Remotely unlock the KEYSAFE from anywhere in the world with an additional Wi-Fi gateway.

RELIABLE, ROBUST ACCESS.

A commercial-grade padlock designed for harsh Australian conditions, featuring an IP68-rated boron steel body, Bluetooth and PIN access, and a rechargeable battery lasting up to a year. Built for remote and multi-user applications, it operates completely offline using Igloohome's secure AlgoPIN™ technology.

- Body: Zinc Alloy, stainless steel, rubber
- Shackle: Boron steel
- Modes of access: Pin Code, Bluetooth
- Power type: Rechargeable lithium battery
- Battery life: Up to 12 months*

IGSP2E



No Wi-Fi required!

SMART PRO ADD ON CABLES



ADVANCED DIAGNOSTICS

Over time Advanced Diagnostics have developed a range of add-on accessories for key programming on different vehicles, in particular for when all keys are lost. Ranging from emulators, ignition bypass and direct connection to ECU these solutions make easy work of an otherwise challenging situation.



SMART Pro Mercedes Kit (Including Programmer + 3 Keys)
SD755333ZB



SMART Aerial Plus Cloning Machine for Mobile Cloning of Fixed and Crypto Transponder Keys - AD245 D854589AD
SD854589AD



SMART Pro Mercedes All Keys Lost Cable Kit - ADC2600
SD756298AD



SMART Pro Cable VAG Ignition Bypass - ADC187
ADC187



SMART Pro Cable ADC219 VAG Instrument Cluster Reset
ADC219



SMART Pro Chrysler Group 2018+ Star Connector Cable - ADC2011
SD753084AD



SMART Pro Chrysler Group 2018+ Star Connector Cable - ADC2012
SD753920AD



SMART Pro Bypass Cable for Toyota - ADC2021 D756924AD
SD756924AD



SMART Pro Bypass Cable for Ford - ADC2025 D757871AD
SD757871AD



SMART Pro OBD Master Cable 90° - ADC2013
SD755648AD



SMART Pro Bypass Cable for Renault - ADC2017
SD755649AD



SMART Pro Emulator for Toyota (DST) When All Keys Lost - ADC2015
SD755650AD



SMART Pro Toyota H Bladed All Keys Lost Cable - ADC2016
SD755976AD



SMART Pro Bypass Cable for Toyota - ADC2018 D756295AD
SD756295AD



SMART Pro Emulator for Ford and Toyota When All Keys Lost - ADC2020 D756922AD
SD756922AD



**ADVANCED
DIAGNOSTICS**



LSC 100 YEAR SMART PRO TOKEN SPECIAL 12 MONTH SUBSCRIPTION



30% OFF

SD755115AD*



INVEST NOW AND SAVE!

SMALL BUSINESS SUPPORT \$20,000 INSTANT ASSET WRITE-OFF

Temporary increase of the instant asset write-off limit from \$1,000 to \$20,000 for the 2025–26 income year.

On 4 April 2025, the government announced it will continue to provide support for small businesses by extending the \$20,000 instant asset write-off limit until 30 June 2026.

Under the measure small businesses with an aggregated turnover of less than \$10 million, can deduct the full cost of eligible depreciating assets costing less than \$20,000 that are first used or installed ready for use between 1 July 2025 and 30 June 2026.

The \$20,000 limit under the measures applies on a per asset basis, so small businesses can instantly write off multiple assets. Investing in a new key machine such as the Silca EvoX, Bravo Professional, Marker2000, Futura Edge or others could give you an instant write off.



This information is a general summary and not advice. Speak to your Accountant or Tax Professional before making a purchasing decision to ensure these rules apply to you and are suitable for your business and financial situation.

ALL-IN-ONE, ELECTRONIC KEY CUTTING MACHINE

SERIES



Silca's iconic key cutting machine is now faster, quieter and even easier to use.



CARBIDE CUTTER FOR FLAT KEYS

Featuring a special coating, this carbide cutter will last longer, and will cut thousands of keys - earning you big dollars before it needs replacement

FEATURES:



QUIET OPERATION



NEW CARBIDE CUTTER



Ethernet or single Wifi connection



All-in-one

FUTURA *M* SERIES

Thanks to the familiar, easy to use and powerful software, the ability to cut virtually any key, in a single, compact, fast and reliable machine makes Future M-Series the go-to choice for you.

Futura M features a double cutting station meaning flat, cruciform, laser and dimple keys, both residential and automotive, can all be cut using a single machine.

The wide range of optional accessories available further increases the machine's cutting capabilities allowing almost any residential and vehicle key on the market to be cut.

New with the Futura M-Series are an integrated monitor, new and quieter motors, and a carbide cutter. The tablet is gone, streamlining networking and updates, and removing the need to charge and manage a separate device.



INTEGRATED MONITOR

Industrial-grade 10 inch, colour touch-screen display, adjustable to give the perfect view.



EASY TO USE SOFTWARE

Proven, familiar, intuitive user interface with one-touch software updates via the internet.

FUTURA M-SERIES CAN CUT ALL OF THESE KEYS:

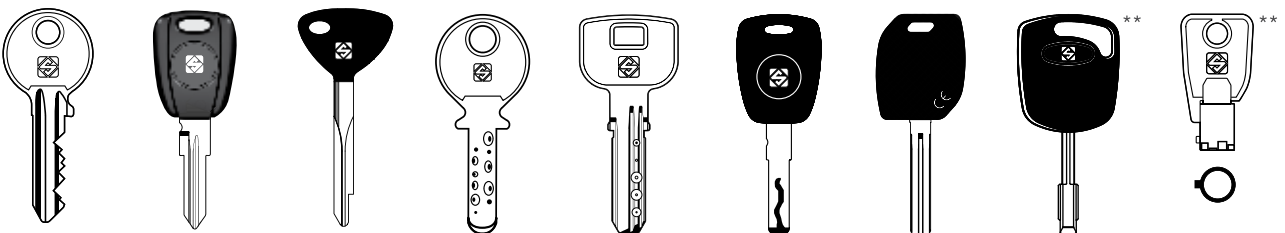

** Keys cut with optional accessory for M400 and M600 models

AUSTRALIA'S MOST TRUSTED COMMERCIAL PADLOCK



Security Tech Germany

**PRECISION
GERMAN
ENGINEERING**



Tested and Australian Standard Certified AS4145.4 2002

With the largest range of options & accessories available, custom etching or embossing & Australian Standard Certified it's no wonder the ABUS 83/45 & 83/50 are the locksmiths' padlock of choice. The AS4145.4 2002 standard applies to padlocks used in conjunction with padlock fittings.

- **PHYSICAL SECURITY** is classified under 10 levels, based on performance tests that simulate attack. The security rating is based on the lowest test result achieved.
- **CORROSION RESISTANCE** is classified under 5 levels, based on standard accelerated corrosion tests.

ABUS 83/45

Physical Security Rating SP6

Corrosion Resistance Rating C4



ABUS 83/50

Physical Security Rating SP6

Corrosion Resistance Rating C4



These models are SEEPL Certified for use in Australian Government facilities.



ABUS 83/55 Series
Security Level 3 (SL3)



ABUS 83/60 Series
Security Level 3 (SL3)



ABUS 83/80 Series
Security Level 4 (SL4)

ADI SECURITY KEY BOXES

ADI security wall mounted key boxes are small, strong and reliable. They are ideal for storing keys and access cards for easy and quick access. We have our two main fully assembled boxes fitted with either a 201 cylinder or a cam lock. Less cylinder versions are supplied with an individual accessory kit specifically designed for the cylinder configuration.



ADI Security Key Box Hinged, with 201 Cylinder



ADI Security Key Box Hinged, with 22mm Cam Lock
NMB112CAM



suits 003 201 cylinder
ADI Security Key Box Hinged, Less Cylinder with Cam
NMB112003LC



suits MT5 201 cylinder
ADI Security Key Box Hinged, Less Cylinder with Cam
NMB112MT5LC



suits Abloy® Protec 201 cylinder
ADI Security Key Box Hinged, Less Cylinder with Cam
NMB1112EMLC

785 HEAVY DUTY EURO MORTICE LOCK



PROTECTOR
SERIES

Enjoy the benefits of quality European made PROTECTOR Series Mortice Locks

PROTECTOR Series range of Euro mortice locks have always been recognised by Locksmiths and the Security industry for their quality & reliability.

LSC have been supplying PROTECTOR Locks for decades and Locksmiths love the fact they “have never changed and always been reliable”.

With numerous models to select from with multiple backsets and finishes, its no wonder Locksmiths choose PROTECTOR Locks.

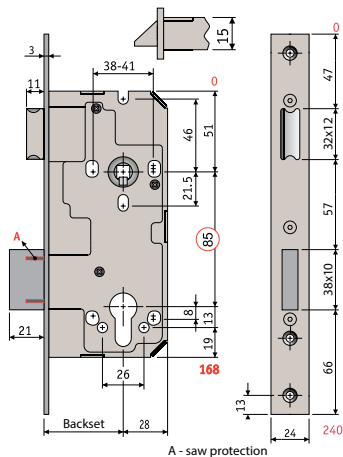

- Euro cylinder operated heavy duty mortice lock
- 45, 50, 55 or 60 mm backsets
- Pitch 85 mm
- Face plate 240 (L) x 23 mm (W)
- Case size 168 (H) x 88 mm (D) includes face plate
- Handle fixing centres 41 mm
- Easily reversible without opening the case
- 8 mm spindle hub
- Double throw 21 mm deadbolt with anti-saw protection
- Key retracts latch
- Supports a fixed cam Euro cylinder
- Supplied less cylinder
- Supplied less escutcheons
- Strike 200 (L) x 24 mm (W) with 16 mm lip
- Finished in satin stainless steel or satin brass
- More finishes available in accessory packs

For more information visit the LSC website



Series 748

- | | |
|-------------------------------|-------------------------------|
| ● 45 mm Backset:
PR78545SB | ● 50 mm Backset:
PR78550SB |
| ● 45 mm Backset:
PR78545SS | ● 50 mm Backset:
PR78550SS |
| ● 55 mm Backset:
PR78555SB | ● 60 mm Backset:
PR78560SB |
| ● 55 mm Backset:
PR78555SS | ● 60 mm Backset:
PR78560SS |

HAMILTON

Elegant, Fire-Rated, DDA Compliant Smart Lock with Fingerprint Access

Access just got smarter!
This versatile, robust & contemporary smart lock is the pinnacle of intelligent trade-grade security.

 **24 MONTH WARRANTY**  **IP66 WATER RESISTANT**

 **FIRE-RATED**  **DDA COMPLIANT**



Fingerprint



Phone Access
(Bluetooth)



PIN Code



Fobs & Cards



Mechanical Key



Matt black or satin nickel
FINISH

35mm - 54mm
DOOR THICKNESS

260mm (H) x 45mm (W) x 23mm (D)
LOCK CASE DIMENSIONS

Tubular latch or mortice lock
LOCK TYPE

IP66 on external lock housing
WATER RESISTANCE RATING (IP CLASS)

2 hour Firecore & E-Core doors
FIRE RATED

DDA compliant lever design
DISABILITY COMPLIANCE

300,000
CYCLE TESTED

Australian Registered Design No. 202316722
AUSTRALIAN DESIGNED

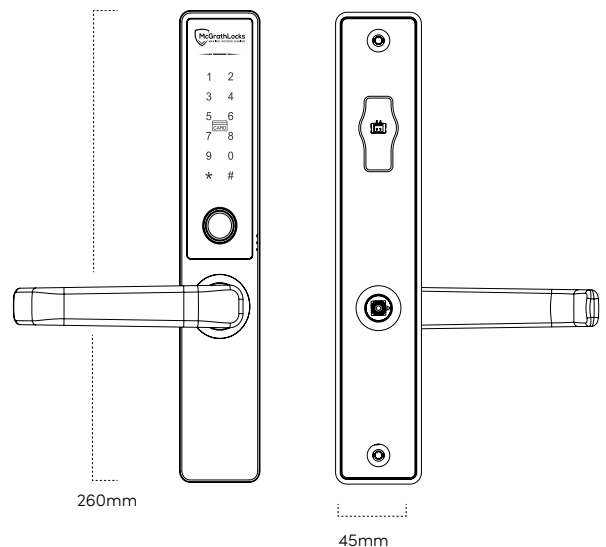

MLHAMSNT6070
MLHAMBKT6070





GET AHEAD BEFORE EOFY WITH LSC AND SALTO

Looking to secure stock, win more projects, and avoid delays before the end of the financial year? LSC offers a comprehensive range of SALTO products, supporting both day-to-day supply and large-scale projects. With over a decade of experience alongside SALTO, LSC knows what it takes to keep jobs moving.



Why partner with LSC for SALTO?

- Trusted SALTO distributor since 2012 with early access to new solutions
- Australia's largest local holding of SALTO stock, ready for immediate dispatch
- National footprint with strong local branch support

Real support, beyond supply:

- 60 plus sales team, including 26 dedicated BDMs and Account Managers
- Dedicated 1300 technical support line
- National SALTO certified tech support team
- National Training Coordinator with tailored training programs available

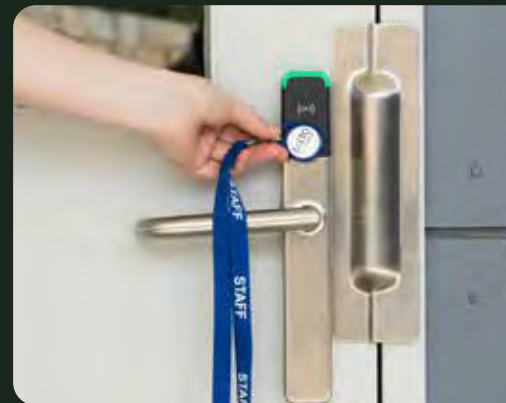

As a third generation, family-owned Australian business with 100 years of history, LSC is focused on long term partnerships and customer success.

Stock up before EOFY and stay ahead of demand.

Speak with your LSC representative today.

MAGLOCKS BY NEPTUNE SECURITY PRODUCTS



Neptune Maglock Single Door, 500kg, Monitored, Black
NEML500MB

RELIABLE LOCKING PERFORMANCE

For installers looking to stay competitive while still supplying reliable hardware, Neptune maglocks provide a smart balance of quality and affordability.

When it comes to access control installations, reliability matters. The Neptune Security Products range of magnetic locks delivers dependable performance, solid build quality, installer-friendly design and all at a highly competitive price point.

Built for everyday commercial and residential applications, Neptune maglocks are designed to provide strong holding force, consistent operation, and long-term durability across a wide range of door types and environments. Whether you're securing office entries, apartment common areas, gates, or internal access-controlled doors, the Neptune range offers a practical and cost-effective solution without compromising on performance.

Key features across the range include:

- Monitored
- Available in Silver and Black
- Fire Rated (select models)
- Durable construction for long service life
- Easy installation with a wide range of accessories available
- Clean, professional appearance suitable for modern installations
- Excellent value for projects where performance and budget both matter



**2 HOUR
FIRE RATED**
Neptune Maglock Single Door, 280kg, Monitored
NEML280M



Neptune Maglock Double Door, 280kg, Monitored, Black
NEML280DMB



Neptune Maglock Double Door, 500kg, Monitored
NEML500DM



Neptune Waterproof Maglock Single Door, 280kg, Monitored
NEWML280M



Neptune L&Z Bracket to suit NEML280MB, Black
NEMLB3B



Neptune Double L&Z Bracket to suit NEML500DM
NEMLB6D

JOIN US AT THE MLAA CONFERENCE 2026

Registrations are now open for the 45th Annual MLAA Trade Expo & Conference, taking place at Marvel Stadium, Melbourne from 1–3 October. Under the theme Unlocking Pathways, this three-day event brings together the best of our industry, featuring expert speakers, hands-on learning, innovation, networking, and the always-popular Gala Dinner & Awards Night.

With early bird pricing available until 30 June, now's the time to lock in your spot.

As part of our 100-year celebration, LSC will be there in a big way - expect special giveaways, exclusive activations, international guests and a few surprises along the way. It's set to be a standout event you won't want to miss!

45TH ANNUAL
TRADE EXPO &
CONFERENCE

1-3 OCTOBER 2026
MARVEL STADIUM, MELBOURNE



Dahua ²⁰²⁶ Discovery Day

Dahua Discovery Day Shines in North Melbourne

We recently hosted a Dahua Discovery Day at our North Melbourne branch, making the most of a beautiful sunny day with a great turnout of customers.

The event featured live demonstrations of the latest technology, including the WizSense NVR with WizSeek functionality and Dahua's new face recognition door station, alongside valuable product updates from the team.

Attendees enjoyed a BBQ lunch, giveaways, and a "Spend & Get" promotion, with Shell eGift cards up for grabs.

A big thank you to everyone who joined us and helped make the day a success.





The Melbourne Home Show 2026

The Melbourne Home Show ran from 17-19 April at the Melbourne Convention and Exhibition Centre, and it was one of the strongest showings yet for the McGrath Smart Locks brand.

Our team joined McGrath Smart Locks at the event, helping to exhibit across all three days. The stand was positioned right near the front entrance, providing excellent exposure to the tens of thousands of homeowners, renovators and new home buyers passing through each day. It was also a great opportunity to showcase McGrath's fresh new branding, which was very well received.

Alongside our team, local qualified locksmiths joined the stand each day, something that continues to set McGrath apart and reinforces their reputation as the locksmith's choice for trade grade smart locks.

The McGrath Trade Grade range was front and centre throughout the show, including newer products like the Grange, Kedron and Ashgrove smart deadbolts. Accessories such as the Keybox, Z Chip and Keypads were also on display, positioning McGrath as a complete smart locking system for Aussie homes.

Amongst several smart lock competitors at the show, McGrath stood out for all the right reasons; an Australian-designed range trusted by locksmiths, a 24-month warranty, and unique features tailored for Australian applications, including fire rated, IP66 and DDA-compliant smart locks.

Consumer response to the range was outstanding, visitors were blown away by the quality and features on offer, giving us great confidence that McGrath's trade-grade products resonate just as strongly with homeowners as they do with locksmiths. The new catalogue proved a real hit as well.

McGrath Smart Locks are only sold by LSC to trade professionals, not direct to consumers. So we're thrilled for McGrath to have generated business for locksmiths across the weekend, referring homeowners directly to the locksmiths who stand behind the quality of our trade-grade range, designed here in Australia for Australian homes.



home show

HAPPY CUSTOMERS



MOSMAN LOCKSMITHS (NSW)

Here is a photo of LSC's Paul Gliddon passing on the prize of an NRL ball to Lachlan Beck from Mosman Locksmiths for a recent NSW based ABUS promotion.



AMALGAMATED LOCKSMITHS (QLD)

Louis Black from Amalgamated Locksmiths is all smiles with a new Silca Flash 008 machine fitted in his service vehicle.



ALERT LOCKS & SECURITY (NSW)

Pictured here are some happy NSW customers who scored a Steeden NRL Rugby Ball with selected ABUS purchases.



AMALGAMATED LOCKSMITHS (QLD)

Amalgamated Locksmiths in Brisbane spent up big on Brava to take advantage of the Free Fuel Friday promo. Louis is pictured with a stack of well-earned fuel vouchers





Creative Keys at LSC

RESTOCKED FOR FOOTY SEASON



*Selected NRL key designs shown may be unavailable or temporarily out of stock.



Proudly produced under license by Creative Keys Limited.

TERMS & CONDITIONS

Product features and pricing in this newsletter are subject to change without notice. Special promotional prices advertised here are for the month the newsletter has been published. However, some offers may commence on or extend beyond the promotional period. Most products have been photographed in-house and are identical to what you will receive. Information presented in this newsletter has been checked and is believed to be correct at the time of printing, however, errors and omissions may occur. LSC can not guarantee prices, specifications, or features of products that may change after printing.